

DESIGN + ENGINEERING  
GROHE GERMANY

99.0285.031/ÄM 233736/02.17

www.grohe.com

Pure Freude an Wasser

GROHE

WAVE COSMOPOLITAN

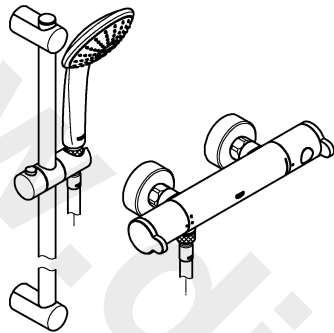

34 537

GET

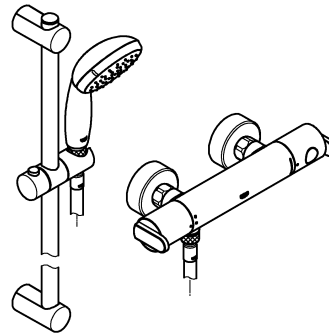

34 545

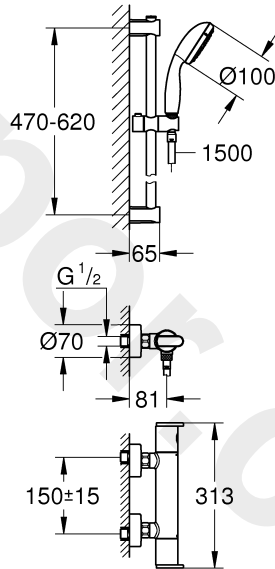
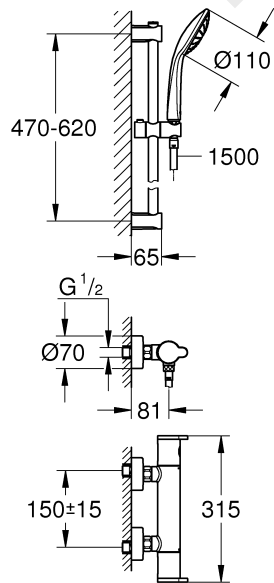

.....1



.....3



....4-7



.....8



.....2



.....3



GB

....5-6



.....9



34 537

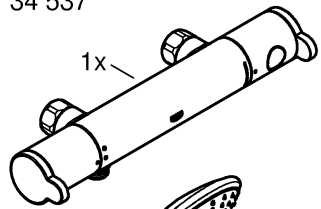

1x

34 545

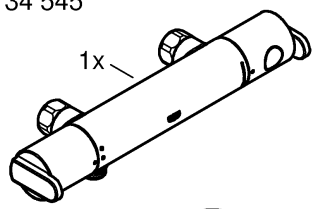

1x

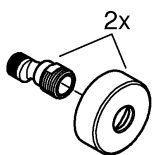
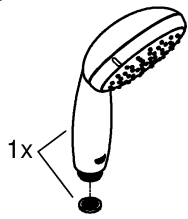
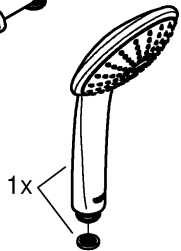

2x

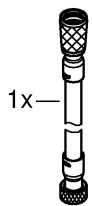

1x

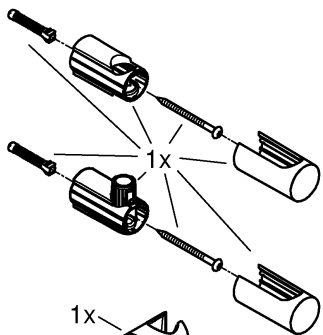

1x

1x

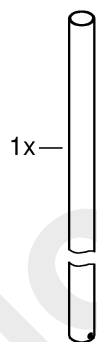

1x



1x



1x

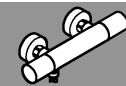
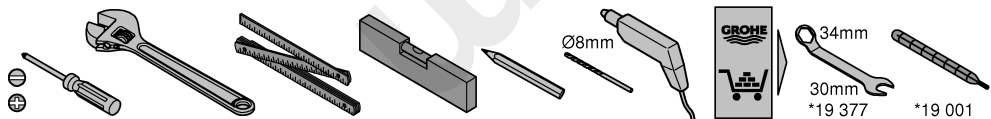

1

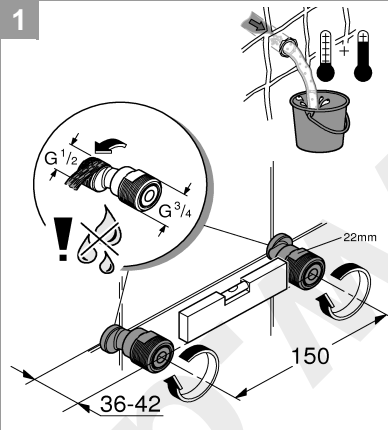

2

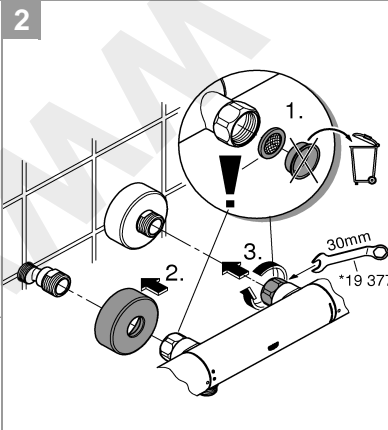

3

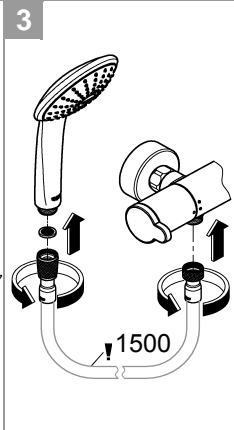

1

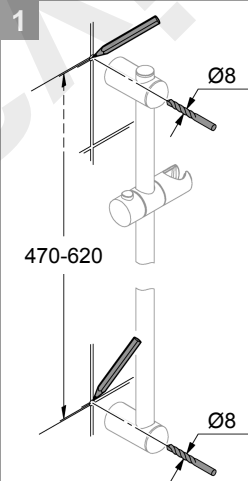

470-620

3

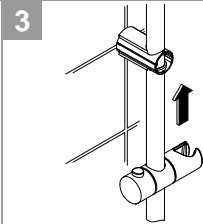

4

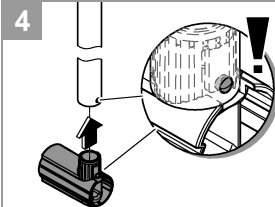

6

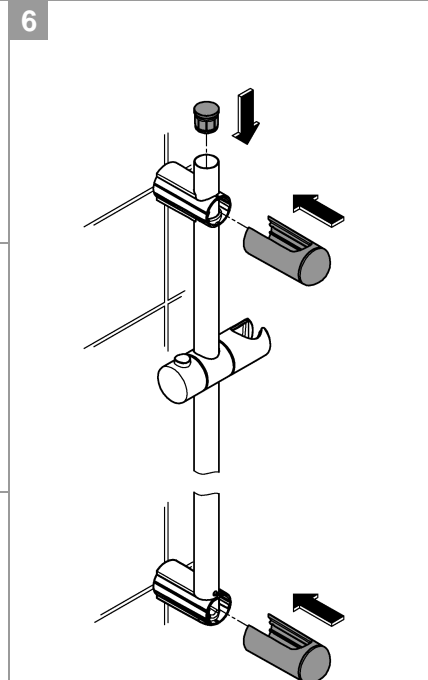

2a

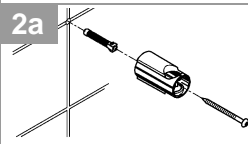

5

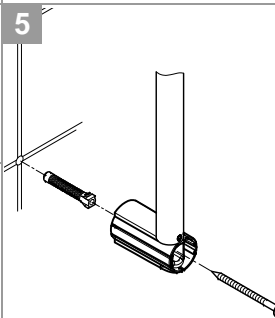

2b

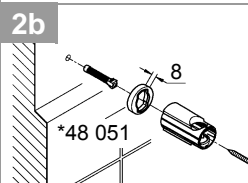

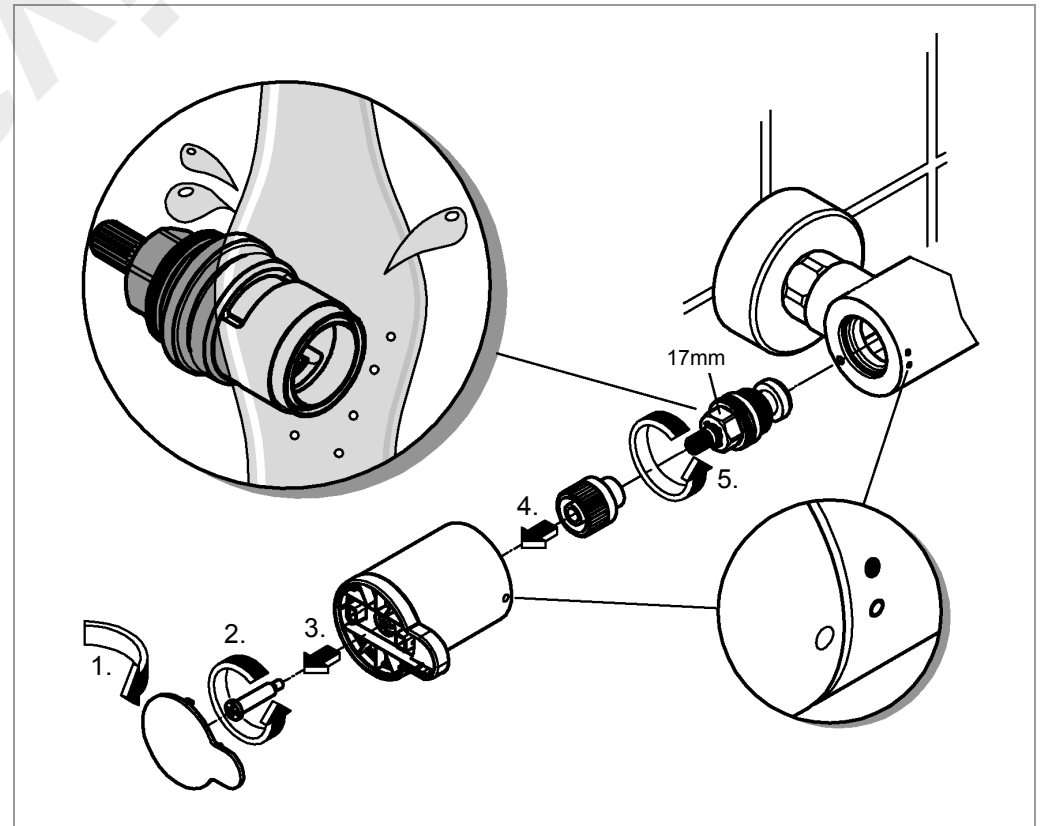
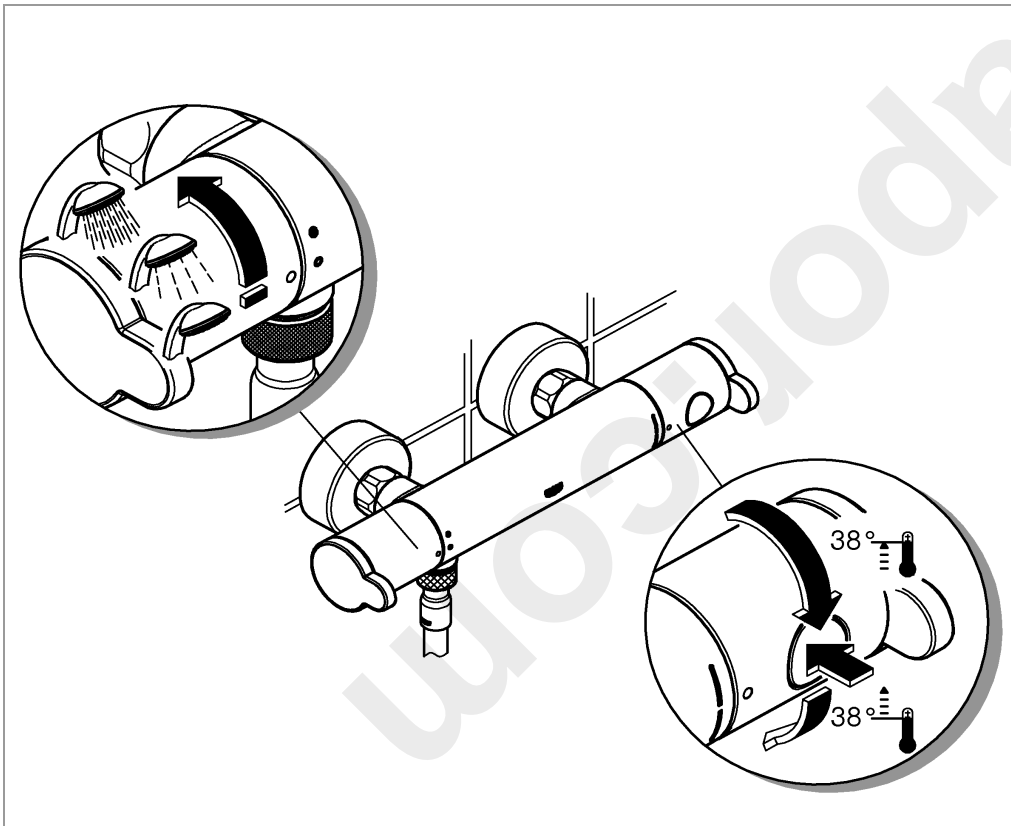
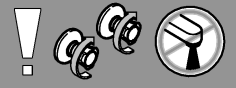
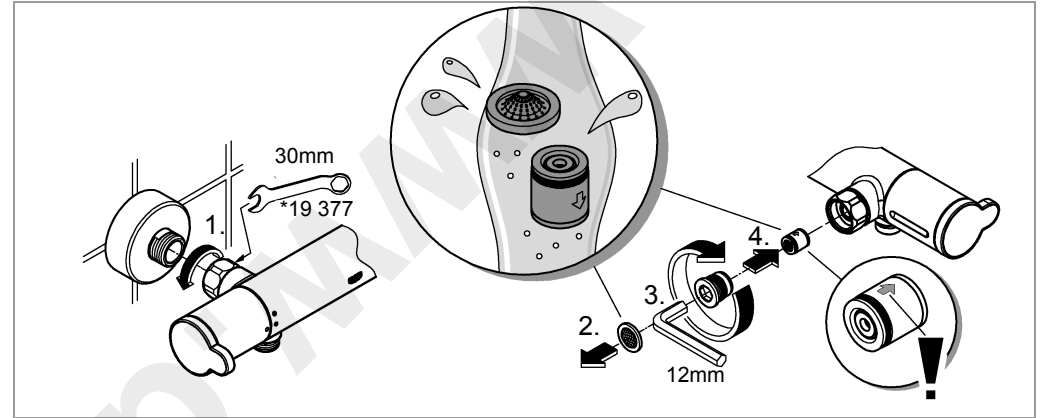
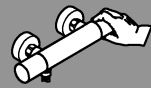
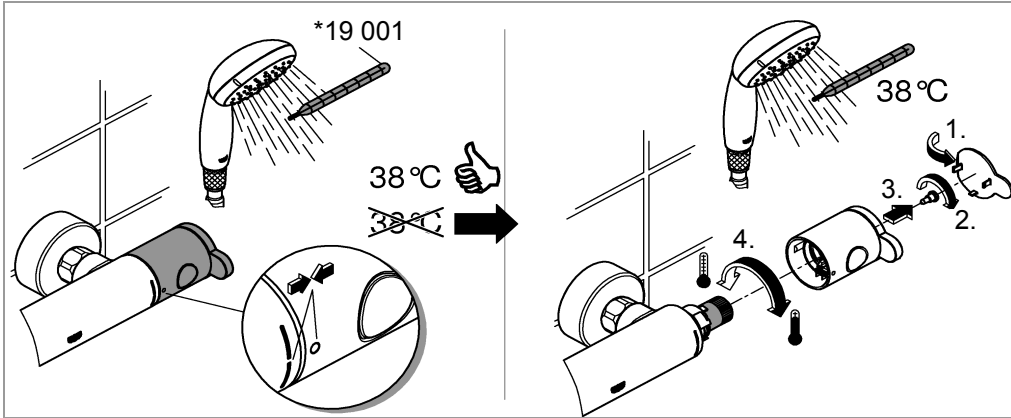
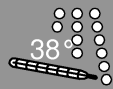



### Safety and important information

This thermostatic valve will suit supplies of:  
Low pressure shower (LP-S).

### Conditions of use TMV2

pressure			max. pressure ratio
Range	cold water	hot water	LP:HP 1:5 or 5:1
low pressure	<1bar		
high pressure	<2bar	<1,2bar	
	2-5bar	<2bar	

**NOTE:** Valves operating outside these conditions cannot be guaranteed by the Scheme to operate as Type 2 valves.

If a water supply is fed by gravity then the supply pressure should be verified to ensure the conditions of use are appropriate for the valve.

### Recommended outlet temperature

- 44 °C for bath fill
- but:
- 41 °C for shower and washbasin
  - 38 °C for bidet

The mixed water temperatures must never exceed 46°C.

The maximum mixed water temperature can be 2°C above the recommended maximum set outlet temperatures.

**NOTE:** 46°C is the maximum mixed water temperature from the bath tap. The maximum temperature takes account of the allowable temperature tolerances inherent in thermostatic mixing valves and temperature losses in metal baths.

### It is not a safe bathing temperature for adults or children.

The British Burns Association recommends 37 to 37.5°C as a comfortable bathing temperature for children. In premises covered by the Care Standards Act 2000, the maximum mixed water outlet temperature is 43°C.

The thermostatic mixing valve will be installed in such a position that maintenance of the TMV and its valves and the commissioning and testing of the TMV can be undertaken.

Requirements shall be verified against the original set temperature results once a year.

The installation of thermostatic mixing valves must comply with the requirements of the Water Supply (Water Fittings) Regulations 1999.

The fitting of isolation valves is required as close as is practicable to the water supply inlets of the thermostatic mixing valve.

### Notes

If there is a residual flow during the commissioning or the annual verification (cold water supply isolation test), then this is acceptable providing the temperature of the water seeping from the valve is no more than 2°C above the designated maximum mixed water outlet temperature setting of the valve.

### Application

Thermostat mixers are designed for hot water supply via pressurised storage heaters and, utilised in this way, provide the best temperature accuracy. With sufficient power output (from 18 kW or 250 kcal/min), electric or gas instantaneous heaters are also suitable.

Thermostats **cannot** be used in conjunction with non-pressurised storage heaters (displacement water heaters).

All thermostats are adjusted in the factory at a flow pressure of 2:2 bar on both sides.

Should temperature deviations occur on account of special installation conditions, the thermostat must be adapted to local conditions (see Adjusting).

### Specifications

Test pressure	16 bar
Flow rate	
0,1 bar	approx. 5,5 l/min
0,2 bar	approx. 10 l/min
3 bar	approx. 42 l/min

Max. water temperature at hot water supply	70 °C
Cold water connection	right
Hot water connection	left
Minimum flow rate	= 5 l/min

If static pressure is not in necessary level , a pressure reducing valve must be fitted.



### Installation, see page 2.

**Flush piping system prior and after installation of fitting thoroughly** (Consider EN 806)!

Screw-mount the mixer and test the connections for **watertightness**



### Adjusting, see page 3.

Open the shut-off valve and turn temperature handle until safety stop of 38 °C. Check the temperature of the water with a thermometer. If temperature is not 38°C an adjustment is necessary. Turn regulating nut until the water temperature has reached 38 °C.



### Operation, see page 3.

The safety stop limits the temperature range to 38 °C.

The 38 °C limit can be overridden by pressing the button.

### Prevention of frost damage

When the domestic water system is drained, thermostats must be drained separately, since non-return valves are installed in the hot and cold water connections. For this purpose, the mixer must be removed from the wall.



### Maintenance, see page 4 and 7.

Inspect and clean all parts, replace if necessary and lubricate with special grease.

**Shut off hot and cold water supplies.**

**I. Non-return valve**, see page 4.

- Remove connection nipple by turning clockwise (left-hand thread) using a 12mm allen key.

Install in reverse order.

**II. Ceramic headpart**, see page 4.

Install in reverse order.

**III. Thermostatic compact cartridge**, see page 7.

- Loosen screw ring using a 34mm tool
- If necessary, lever out thermostatic compact cartridge via recess.
- Remove screw ring.

Install in reverse order.

**Observe the correct installation position of the thermostatic compact cartridge**, see details.

Readjustment is necessary after every maintenance operation on the thermostatic compact cartridge (see Adjusting).

**Replacement parts**, see page 8 (\* = special accessories).

### Care

For directions on the care of this fitting, please refer to the accompanying Care Instructions.

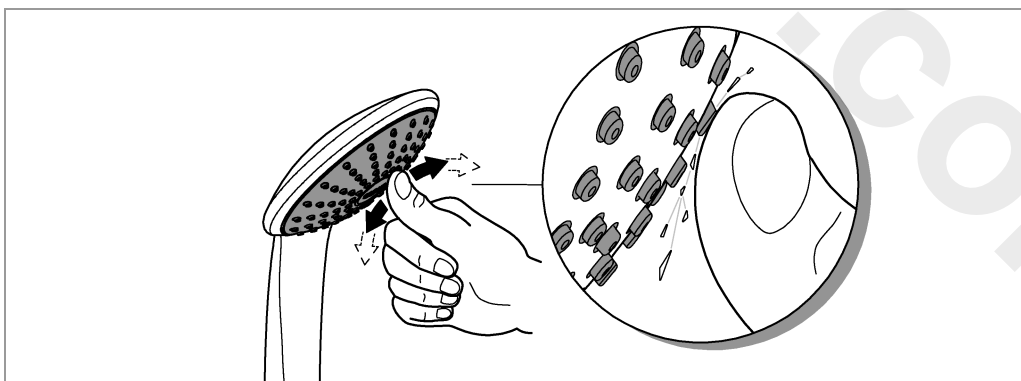
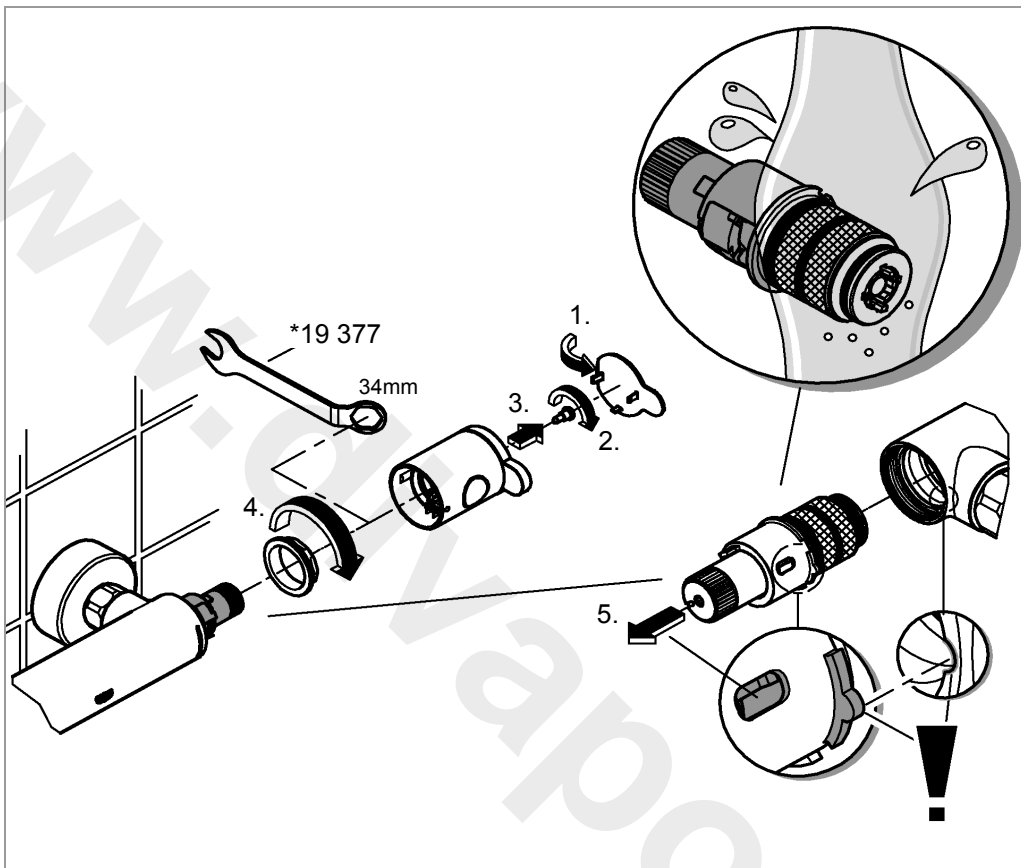

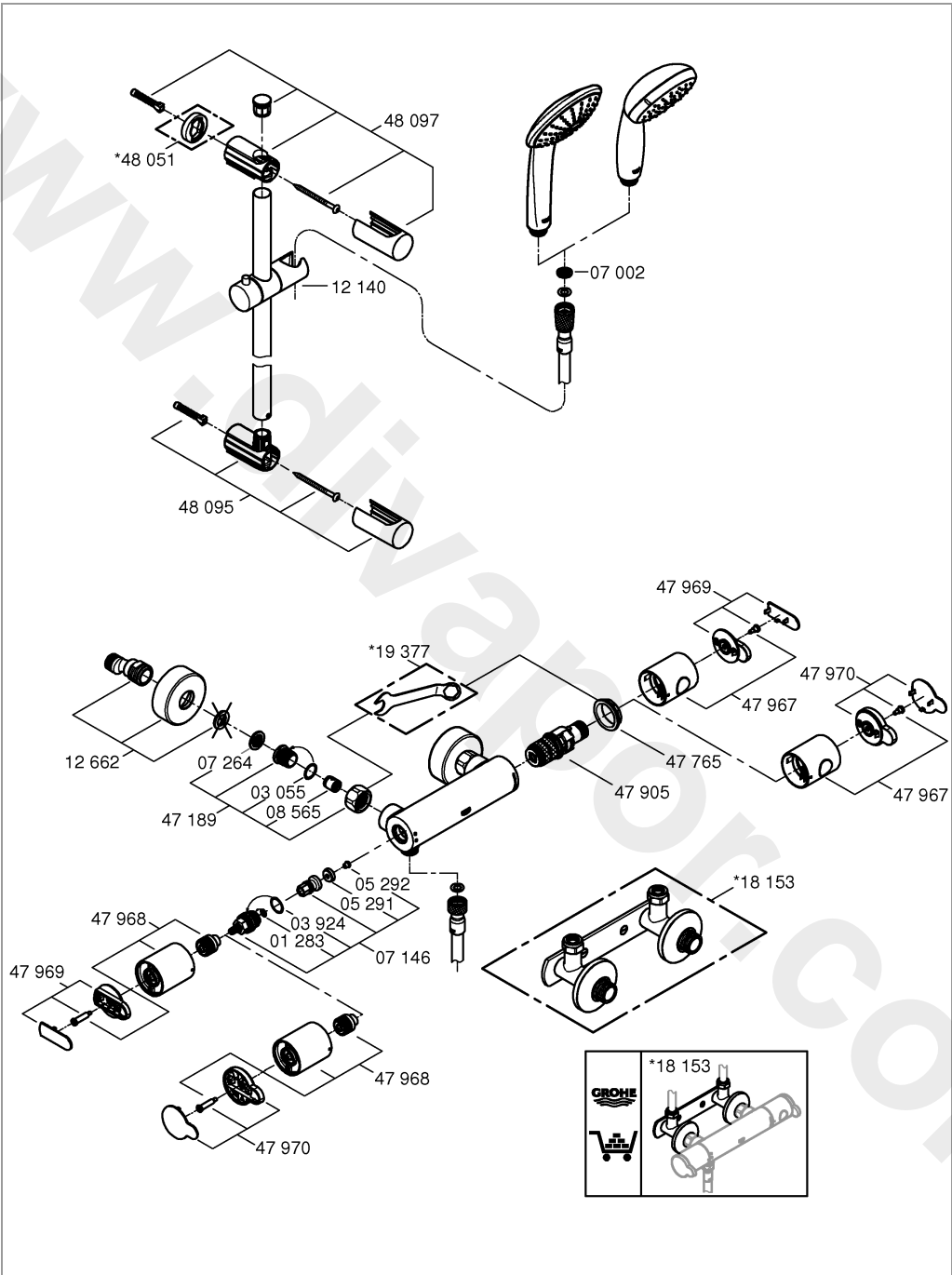

Pure Freude an Wasser

**GROHE**

**(D)**

☎ +49 571 3989 333  
helpline@grohe.de

**(A)**

☎ +43 1 68060  
info-at@grohe.com

**(AUS)**

☎ +(61) 1300 54945  
grohe\_australia@lixil.com

**(B)**

☎ +32 16 230660  
info.be@grohe.com

**(BG)**

☎ +359 2 9719959  
grohe-bulgaria@grohe.com

**(BR)**

☎ 0800 770 1222  
falecom@grohe.com

**(CAU)**

☎ +99 412 497 09 74  
info-az@grohe.com

**(CDN)**

☎ +1 888 6447643  
info@grohe.ca

**(CH)**

☎ +41 44 877 73 00  
info@grohe.ch

**(CN)**

☎ +86 4008811698  
info.cn@grohe.com

**(CY)**

☎ +357 22 465200  
info@grome.com

**(CZ)**

☎ +358 942 451 390  
grohe-cz@grohe.com

**(DK)**

☎ +45 44 656800  
grohe@grohe.fi

**(E)**

☎ +34 93 3368850  
grohe@grohe.es

**(EST)**

☎ +372 6616354  
grohe@grohe.ee

**(F)**

☎ +33 1 49972900  
sav-fr@grohe.com

**(FIN)**

☎ +358 942 451 390  
grohe@grohe.fi

**(GB)**

☎ +44 871 200 3414  
info-uk@grohe.com

**(GR)**

☎ +30 210 2712908  
nsapountzis@ath.forthnet.gr

**(H)**

☎ +36 1 2388045  
info-hu@grohe.com

**(HK)**

☎ +852 2969 7067  
info@grohe.hk

**(I)**

☎ +39 2 959401  
info-it@grohe.com

**(IND)**

☎ +91 1800 102 4475  
customer-care.in@grohe.com

**(IS)**

☎ +354 515 4000  
jonst@byko.is

**(J)**

☎ +81 3 32989730  
info@grohe.co.jp

**(KZ)**

☎ +7 727 311 07 39  
info-cac@grohe.com

**(LT)**

☎ +372 6616354  
grohe@grohe.ee

**(LV)**

☎ +372 6616354  
grohe@grohe.ee

**(MAL)**

info-malaysia@grohe.com

**(MX)**

☎ 01800 8391200  
pregunta@grohe.com

**(N)**

☎ +47 22 072070  
grohe@grohe.no

**(NL)**

☎ +31 79 3680133  
vragen-nl@grohe.com

**(NZ)**

technicalenquiries@paterson  
trading.co.nz

**(P)**

☎ +351 234 529620  
commercial-pt@grohe.com

**(PL)**

☎ +48 22 5432640  
biuro@grohe.com.pl

**(RI)**

☎ 0-800-1-046743  
customer-care-  
indonesia@asia.lixil.com

**(RO)**

☎ +40 21 2125050  
info-ro@grohe.com

**(ROK)**

☎ +82 2 1588 5903  
info-singapore@grohe.com

**(RP)**

☎ +63 2 8938681

**(RUS)**

☎ +7 495 9819510  
info@grohe.ru

**(S)**

☎ +46 771 141314  
grohe@grohe.se

**(SGP)**

☎ +65 6311 3611  
info-singapore@grohe.com

**(SK)**

☎ +420 277 004 190  
grohe-cz@grohe.com

**(T)**

☎ +66 21681368  
(Haco Group)  
info@haco.co.th

**(TR)**

☎ +90 216 441 23 70  
GroheTurkey@grome.com

**(UA)**

☎ +38 44 5375273  
info-ua@grohe.com

**(USA)**

☎ +1 800 4447643  
us-customer-service@grohe.com

**(VN)**

☎ +84 90 9694768  
☎ +84 90 9375068  
info-vietnam@grohe.com

**(AL) (BIH) (HR) (KS)**

**(ME) (MK) (SLO) (SRB)**

☎ +385 1 2911470  
adria-hr@grohe.com

**Eastern Mediterranean,  
Middle East - Africa**

**Area Sales Office:**

☎ +357 22 465200

info@grome.com

**(IR) (OM) (UAE) (YEM)**

☎ +971 4 3318070

grohedubai@grome.com

**Far East Area Sales Office:**

☎ +65 6311 3600

info@grohe.com.sg

**Latin America:**

☎ +52 818 3050626

pregunta@grohe.com

**www.grohe.com**

2016/09/28